

# Cree® XLamp® XR-E LED

## Data Sheet

The XLamp XR-E LED is leading the LED lighting revolution with its unprecedented lighting-class brightness, efficacy, lifetime and quality of light. These lighting-class features enable the XLamp XR-E LED to replace many traditional light sources and save money with energy-efficient light and long lifetimes.

Cree XLamp LEDs bring high performance and quality of light to a wide range of lighting applications, including color-changing lighting, portable and personal lighting, outdoor lighting, indoor directional lighting, commercial lighting and emergency-vehicle lighting.

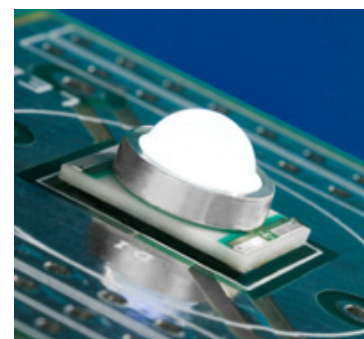

### FEATURES

- Guaranteed minimum flux order codes up to 107 lm in white, 30.6 lm in blue and 67.2 lm in green at 350 mA
- Available in white (2,600 K to 10,000 K CCT), blue, royal blue and green
- Maximum drive current: up to 1000 mA
- Industry's lowest thermal resistance: 8°C/W
- Max junction temperature: 150°C
- Industry-leading JEDEC standard pre-qualification testing
- Reflow solderable – JEDEC J-STD-020C compatible
- Electrically neutral thermal path
- RoHS-compliant
- Lumen maintenance of greater than 70% after 50,000 hours

### Table of Contents

|                                                                       |    |
|-----------------------------------------------------------------------|----|
| Flux Characteristics ( $T_j = 25^\circ\text{C}$ ) - White .....       | 2  |
| Flux Characteristics ( $T_j = 25^\circ\text{C}$ ) - Color .....       | 3  |
| Characteristics .....                                                 | 4  |
| Relative Spectral Power Distribution .....                            | 5  |
| Relative Flux vs. Junction Temperature ( $I_f = 350\text{ mA}$ )..... | 6  |
| Electrical Characteristics ( $T_j = 25^\circ\text{C}$ ).....          | 7  |
| Thermal Design.....                                                   | 7  |
| Relative Flux vs. Current ( $T_j = 25^\circ\text{C}$ ) .....          | 8  |
| Typical Spatial Distribution.....                                     | 8  |
| Reflow Soldering Characteristics .....                                | 9  |
| Notes.....                                                            | 10 |
| Mechanical Dimensions ( $T_A = 25^\circ\text{C}$ ) .....              | 11 |
| Tape and Reel .....                                                   | 12 |
| Dry Packaging and Packaging .....                                     | 13 |

## Flux Characteristics (T<sub>j</sub> = 25°C) - White

The following tables describe the available colors and flux for XR-E LEDs by listing the correlated color temperature or dominant wavelength range for the entire family and by providing several base order codes. It is important to note that the base order codes listed here are a subset of the total available order codes for the product family. For more order codes, as well as a complete description of the order-code nomenclature, please consult the XR-E & XR-C Binning and Labeling document.

| Color         | CCT Range |          | Base Order Codes<br>Min Luminous Flux<br>(lm) |           | Order Code           |
|---------------|-----------|----------|-----------------------------------------------|-----------|----------------------|
|               | Min.      | Max.     | Group                                         | Flux (lm) |                      |
| Cool White    | 5,000 K   | 10,000 K | P4                                            | 80.6      | XREWHT-L1-0000-00901 |
|               |           |          | Q2                                            | 87.4      | XREWHT-L1-0000-00A01 |
|               |           |          | Q3                                            | 93.9      | XREWHT-L1-0000-00B01 |
|               |           |          | Q4                                            | 100       | XREWHT-L1-0000-00C01 |
|               |           |          | Q5                                            | 107       | XREWHT-L1-0000-00D01 |
| Neutral White | 3,700 K   | 5,000 K  | N4                                            | 62.0      | XREWHT-L1-0000-006E4 |
|               |           |          | P2                                            | 67.2      | XREWHT-L1-0000-007E4 |
|               |           |          | P3                                            | 73.9      | XREWHT-L1-0000-008E4 |
|               |           |          | P4                                            | 80.6      | XREWHT-L1-0000-009E4 |
|               |           |          | Q2                                            | 87.4      | XREWHT-L1-0000-00AE4 |
|               |           |          | Q3                                            | 93.9      | XREWHT-L1-0000-00BE4 |
| Warm White    | 2,600 K   | 3,700 K  | N3                                            | 56.8      | XREWHT-L1-0000-005E7 |
|               |           |          | N4                                            | 62.0      | XREWHT-L1-0000-006E7 |
|               |           |          | P2                                            | 67.2      | XREWHT-L1-0000-007E7 |
|               |           |          | P3                                            | 73.9      | XREWHT-L1-0000-008E7 |
|               |           |          | P4                                            | 80.6      | XREWHT-L1-0000-009E7 |

### Notes:

- Cree maintains a tolerance of +/- 7% on flux and power measurements.
- Typical CRI for Cool White & Neutral White (3,700 K – 10,000 K CCT) is 75.
- Typical CRI for Warm White (2,600 K – 3,700 K CCT) is 80.

## Flux Characteristics ( $T_j = 25^\circ\text{C}$ ) - Color

The following tables describe the available colors and flux for XR-E LEDs by listing the correlated color temperature or dominant wavelength range for the entire family and by providing several base order codes. It is important to note that the base order codes listed here are a subset of the total available order codes for the product family. For more order codes, as well as a complete description of the order-code nomenclature, please consult the XR-E & XR-C Binning and Labeling document.

| Color      | Dominant Wavelength Range |          |       |          | Base Order Codes Min Radiant Flux (mW) |           | Order Code           |
|------------|---------------------------|----------|-------|----------|----------------------------------------|-----------|----------------------|
|            | Min.                      |          | Max.  |          | Group                                  | Flux (mW) |                      |
|            | Group                     | DWL (nm) | Group | DWL (nm) |                                        |           |                      |
| Royal Blue | D3                        | 450      | D5    | 465      | 13                                     | 300       | XREROY-L1-0000-00801 |
|            |                           |          |       |          | 14                                     | 350       | XREROY-L1-0000-00901 |
|            |                           |          |       |          | 15                                     | 425       | XREROY-L1-0000-00A01 |

| Color | Dominant Wavelength Range |          |       |          | Base Order Codes Min Luminous Flux (lm) |           | Order Code           |
|-------|---------------------------|----------|-------|----------|-----------------------------------------|-----------|----------------------|
|       | Min.                      |          | Max.  |          | Group                                   | Flux (lm) |                      |
|       | Group                     | DWL (nm) | Group | DWL (nm) |                                         |           |                      |
| Blue  | B3                        | 465      | B6    | 485      | J                                       | 23.5      | XRRELU-L1-0000-00J01 |
|       |                           |          |       |          | K                                       | 30.6      | XRRELU-L1-0000-00K01 |

| Color | Dominant Wavelength Range |          |       |          | Base Order Codes Min Luminous Flux (lm) |           | Order Code           |
|-------|---------------------------|----------|-------|----------|-----------------------------------------|-----------|----------------------|
|       | Min.                      |          | Max.  |          | Group                                   | Flux (lm) |                      |
|       | Group                     | DWL (nm) | Group | DWL (nm) |                                         |           |                      |
| Green | G2                        | 520      | G4    | 535      | P                                       | 67.2      | XREGRN-L1-0000-00P01 |

Note: Cree maintains a tolerance of +/- 7% on flux and power measurements.

## Characteristics

| Characteristics                                                     | Unit    | Minimum | Typical | Maximum |
|---------------------------------------------------------------------|---------|---------|---------|---------|
| Thermal Resistance, junction to solder point                        | °C/W    |         | 8       |         |
| Viewing Angle (FWHM) - white                                        | degrees |         | 90      |         |
| Viewing Angle (FWHM) - royal blue, blue, green                      | degrees |         | 100     |         |
| Temperature coefficient of voltage - white, royal blue, blue, green | mV/°C   |         | -4.0    |         |
| ESD Classification (HBM per Mil-Std-883D)                           |         |         | Class 2 |         |
| DC Forward Current - white ≥ 5000 K, royal blue, blue               | mA      |         |         | 1000    |
| DC Forward Current - white < 5000 K, green                          | mA      |         |         | 700     |
| DC Pulse Current (@ 1 kHz, 10% duty cycle)                          | A       |         |         | 1.8     |
| Reverse Voltage                                                     | V       |         |         | 5       |
| Forward Voltage (@ 350 mA)                                          | V       |         | 3.3     | 3.9     |
| Forward Voltage (@ 700 mA)                                          | V       |         | 3.5     |         |
| Forward Voltage (@ 1000 mA) - white ≥ 5000 K, royal blue, blue      | V       |         | 3.7     |         |
| LED Junction Temperature*                                           | °C      |         |         | 150     |

\* Note: For lumen maintenance data, see the Cree XLamp LED Reliability document.

## Relative Spectral Power Distribution

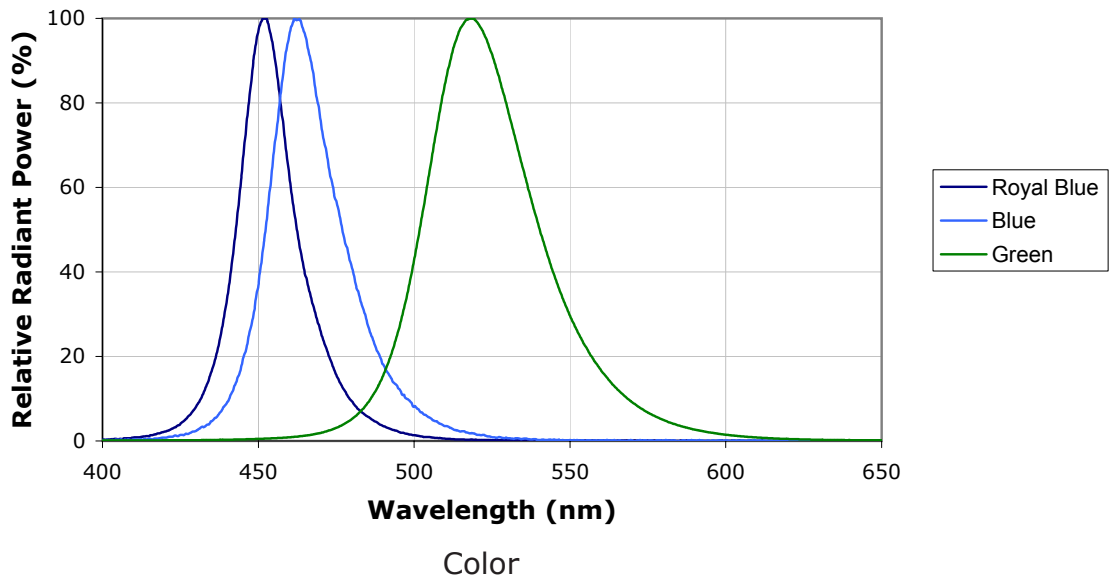
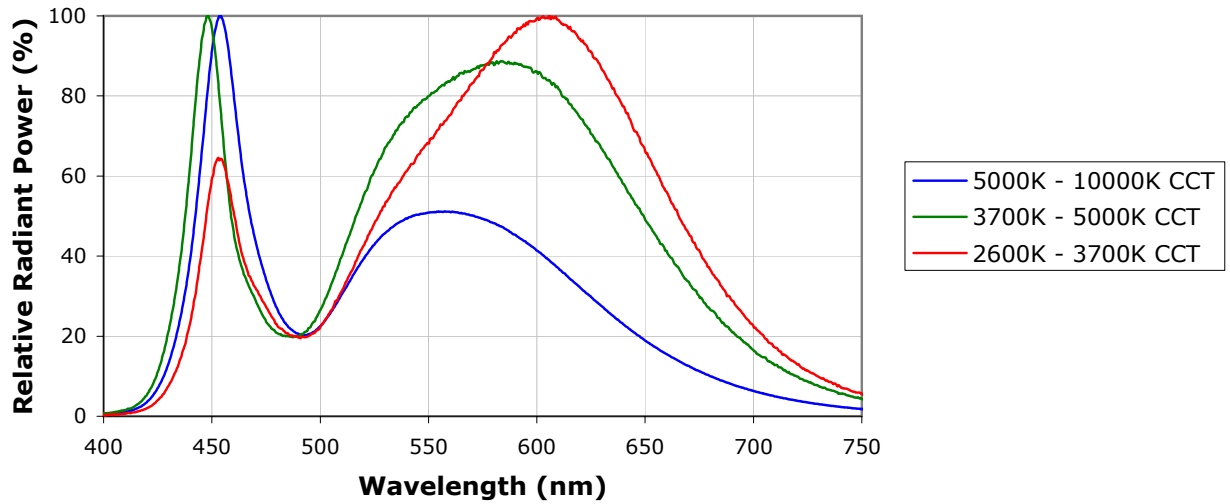

**Relative Flux vs. Junction Temperature ( $I_f = 350$  mA)**

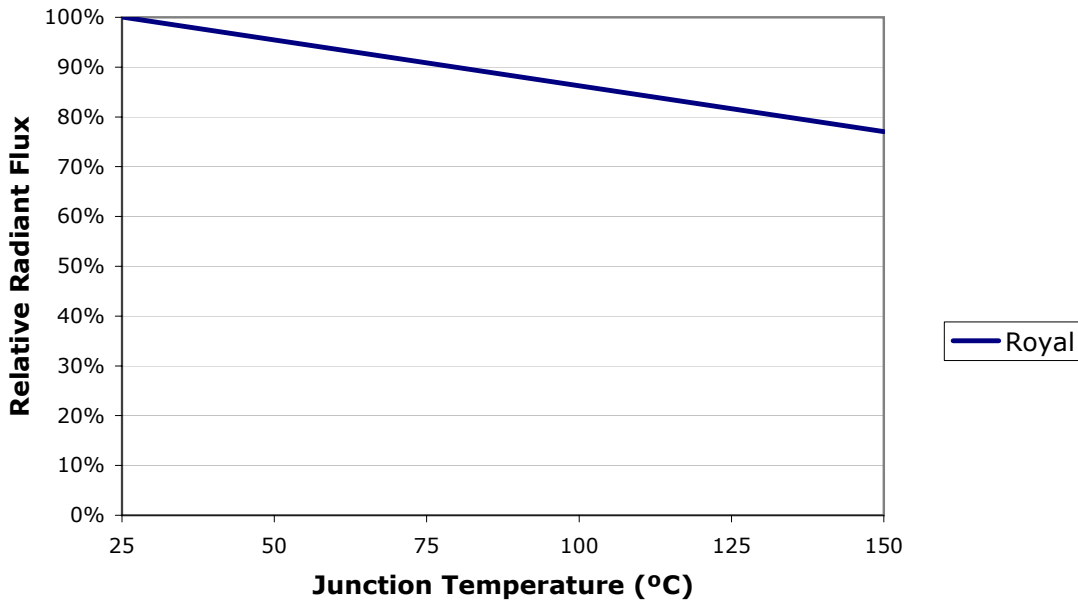
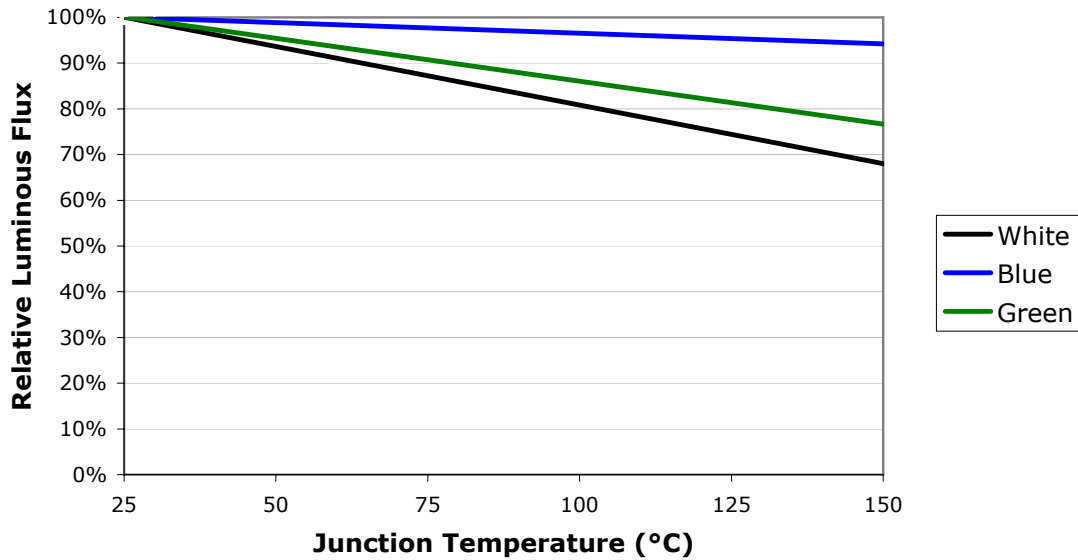

## Electrical Characteristics ( $T_j = 25^\circ\text{C}$ )

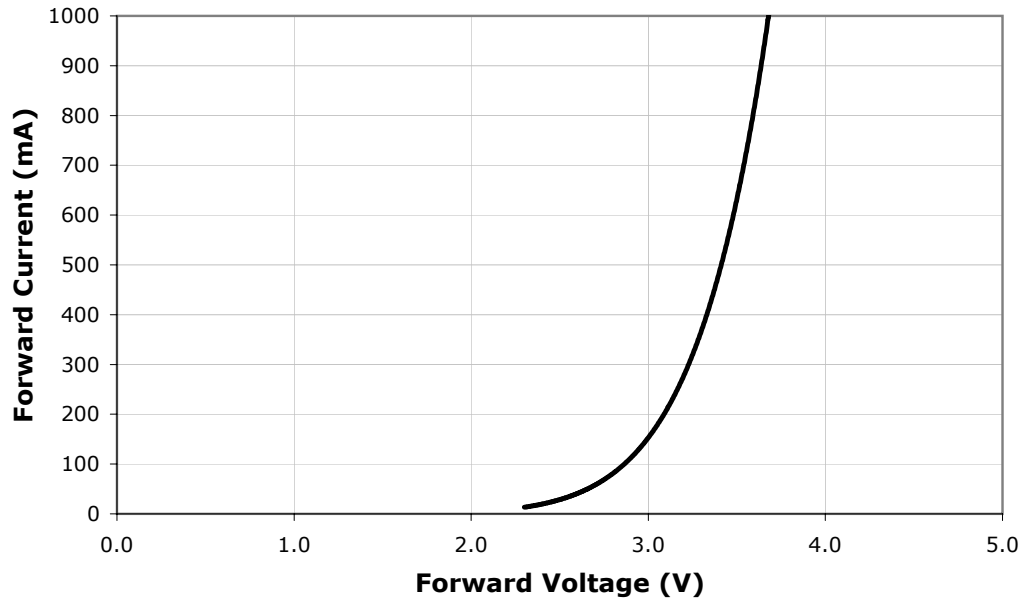

## Thermal Design

The maximum forward current is determined by the thermal resistance between the LED junction and ambient. Given an existing thermal resistance of  $8^\circ\text{C}/\text{W}$  between the junction and the solder point, it is crucial for the end product to be designed in a manner that minimizes the thermal resistance from the solder point to ambient in order to optimize lamp life and optical characteristics.

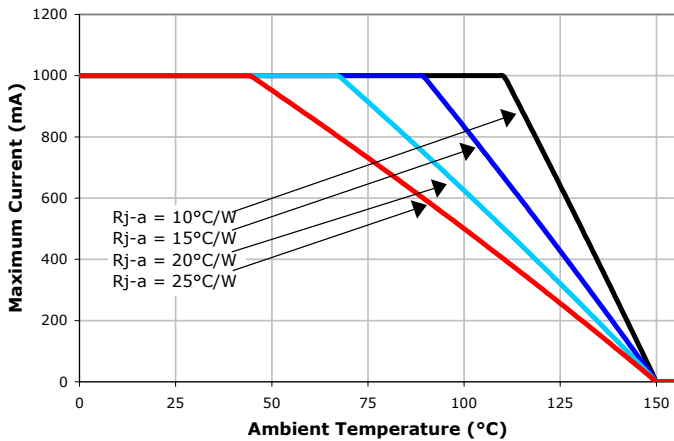

White  $\geq 5,000$  K, Royal Blue, Blue

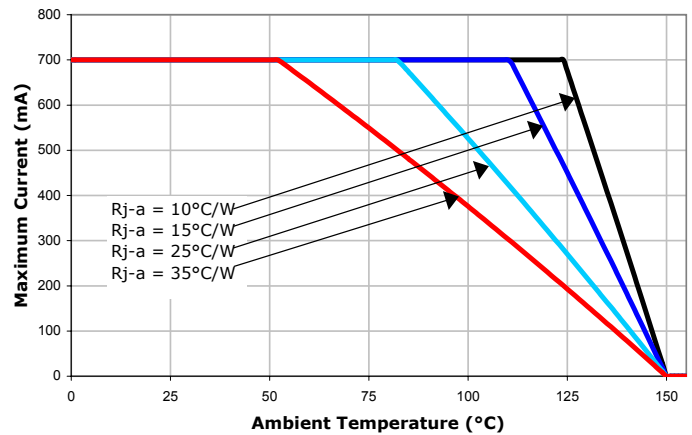

White  $< 5,000$  K, Green

**Relative Flux vs. Current ( $T_j = 25^\circ\text{C}$ )**

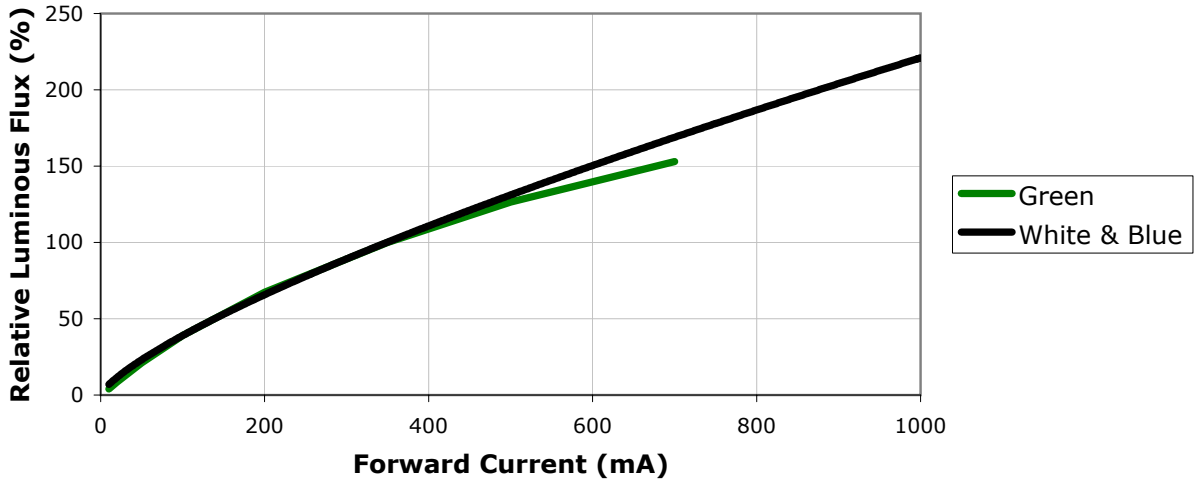

**Typical Spatial Distribution**

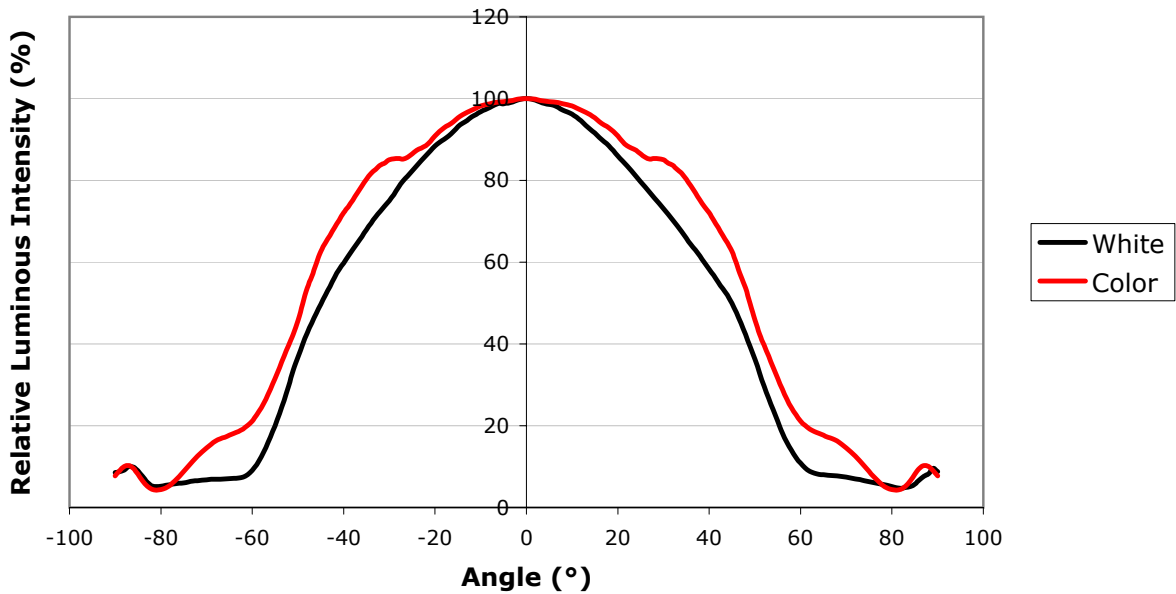

## Reflow Soldering Characteristics

The following reflow soldering profiles are provided for reference. Cree recommends that users follow the recommended soldering profile provided by the manufacturer of the solder paste used. Cree XLamp LEDs are compatible with JEDEC J-STD-020C.

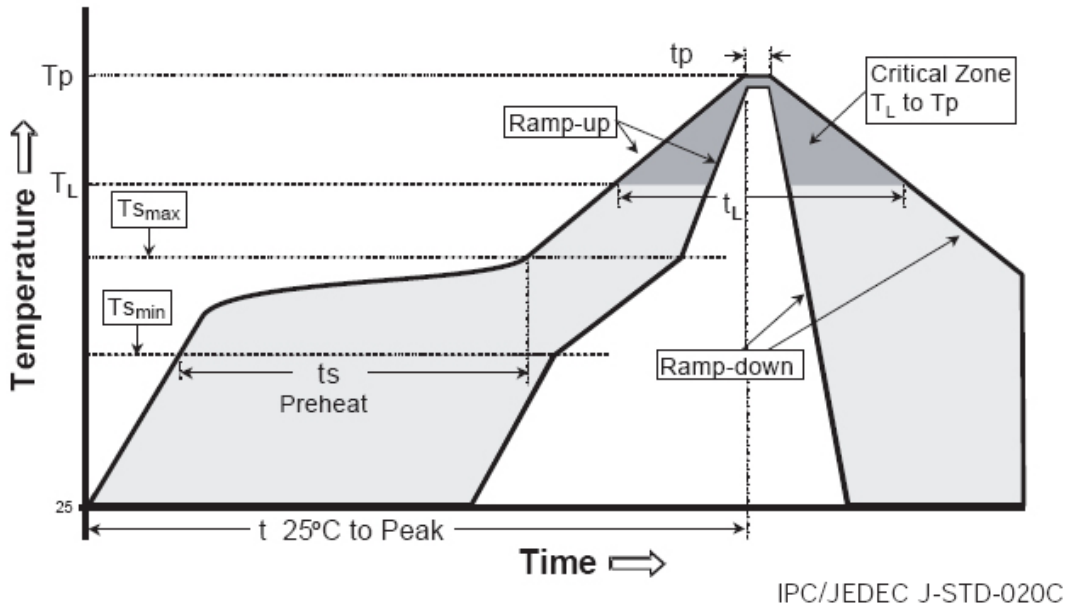

| Profile Feature                                      | Lead-Based Solder | Lead-Free Solder |
|------------------------------------------------------|-------------------|------------------|
| Average Ramp-Up Rate ( $T_{s_{max}}$ to $T_p$ )      | 3°C/second max.   | 3°C/second max.  |
| Preheat: Temperature Min ( $T_{s_{min}}$ )           | 100°C             | 150°C            |
| Preheat: Temperature Max ( $T_{s_{max}}$ )           | 150°C             | 200°C            |
| Preheat: Time ( $t_{s_{min}}$ to $t_{s_{max}}$ )     | 60-120 seconds    | 60-180 seconds   |
| Time Maintained Above: Temperature ( $T_L$ )         | 183°C             | 217°C            |
| Time Maintained Above: Time ( $t_L$ )                | 60-150 seconds    | 60-150 seconds   |
| Peak/Classification Temperature ( $T_p$ )            | 215°C             | 260°C            |
| Time Within 5°C of Actual Peak Temperature ( $t_p$ ) | 10-30 seconds     | 20-40 seconds    |
| Ramp-Down Rate                                       | 6°C/second max.   | 6°C/second max.  |
| Time 25°C to Peak Temperature                        | 6 minutes max.    | 8 minutes max.   |

Note: All temperatures refer to topside of the package, measured on the package body surface.

## Notes

### Lumen Maintenance Projections

Based on internal long-term reliability testing and standardized forecasting methods, Cree projects XLamp LEDs to maintain an average of 70% lumen maintenance after 50,000 hours, provided the LED junction temperature is maintained at or below 80°C.

Please read the XLamp Reliability application note for more details on Cree’s lumen maintenance testing and forecasting. Please read the XLamp Thermal Management application note for details on how thermal design, ambient temperature, and drive current affect the LED junction temperature.

### Moisture Sensitivity

XLamp LEDs are shipped in sealed, moisture-barrier bags (MBB) designed for long shelf life. If XLamp LEDs are exposed to moist environments after opening the MBB packaging but before soldering, damage to the LED may occur during the soldering operation. The following derating table defines the maximum exposure time (in days) for an XLamp LED in the listed humidity and temperature conditions. LEDs with exposure time longer than the time specified below must be baked according to the baking conditions listed below.

| Temperature | Maximum Percent Relative Humidity |     |     |     |     |     |     |
|-------------|-----------------------------------|-----|-----|-----|-----|-----|-----|
|             | 30%                               | 40% | 50% | 60% | 70% | 80% | 90% |
| 30°C        | 9                                 | 5   | 4   | 3   | 1   | 1   | 1   |
| 25°C        | 12                                | 7   | 5   | 4   | 2   | 1   | 1   |
| 20°C        | 17                                | 9   | 7   | 6   | 2   | 2   | 1   |

### Baking Conditions

It is not necessary to bake all XLamp LEDs. Only the LEDs that meet all of the following criteria must be baked:

1. LEDs that have been removed from the original MBB packaging
2. LEDs that have been exposed to a humid environment longer than listed in the Moisture Sensitivity section above
3. LEDs that have not been soldered

LEDs should be baked at 80°C for 24 hours. LEDs may be baked on the original reels. Remove LEDs from MBB packaging before baking. Do not bake parts at temperatures higher than 80°C. This baking operation resets the exposure time as defined in the Moisture Sensitivity section above.

### Storage Conditions

XLamp LEDs that have been removed from original MBB packaging but not soldered yet should be stored in a room or cabinet that will maintain an atmosphere of 25 ± 5°C and no greater than 10% RH (relative humidity). For LEDs stored in these conditions, storage time does not add to exposure time as defined in the Moisture Sensitivity section above.

### RoHS Compliance

The levels of environmentally sensitive, persistent biologically toxic (PBT), persistent organic pollutants (POP), or otherwise restricted materials in this product are below the maximum concentration values (also referred to as the threshold limits) permitted for such substances, or are used in an exempted application, in accordance with EU Directive 2002/95/EC on the restriction of the use of certain hazardous substances in electrical and electronic equipment (RoHS), as amended through April 21, 2006.

### Vision Advisory Claim

Users should be cautioned not to stare at the light of this LED product. The bright light can damage the eye.

**Mechanical Dimensions (T<sub>A</sub> = 25°C)**

All measurements are ±.1mm unless otherwise indicated.

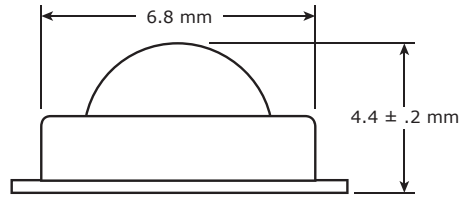
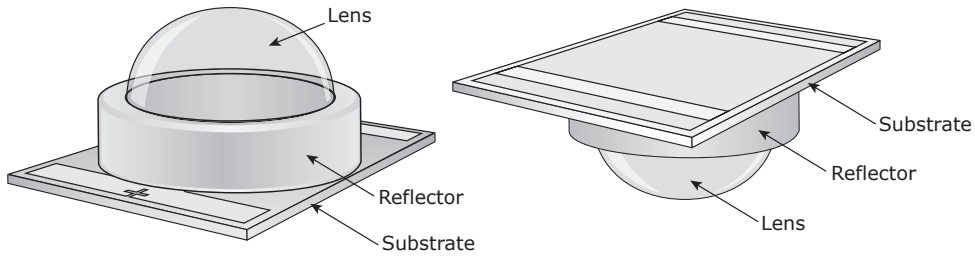

Side View

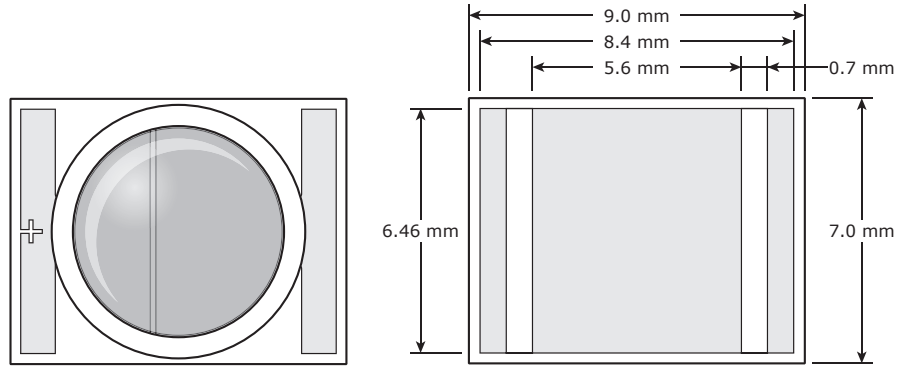

Top View

Bottom View

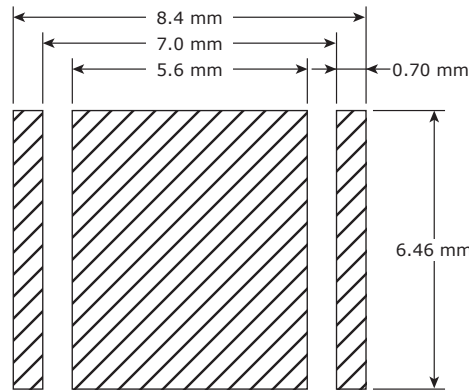

Recommended PC Board Solder Pad

## Tape and Reel

All dimensions in mm.

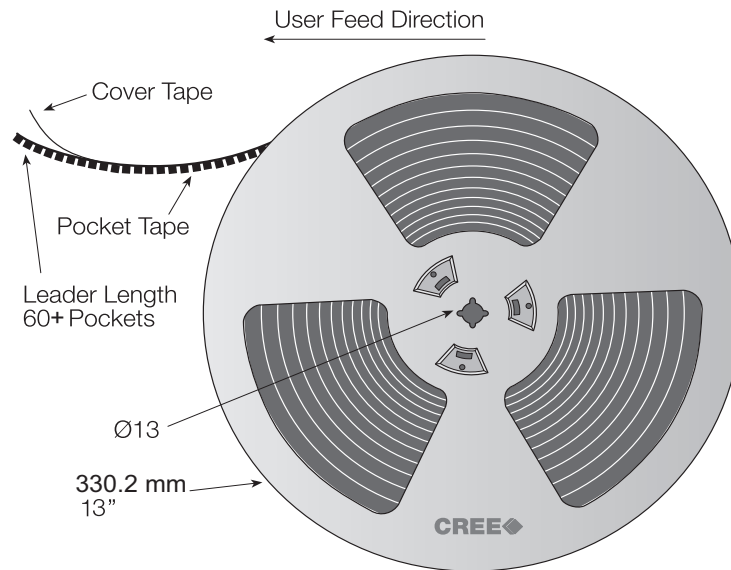
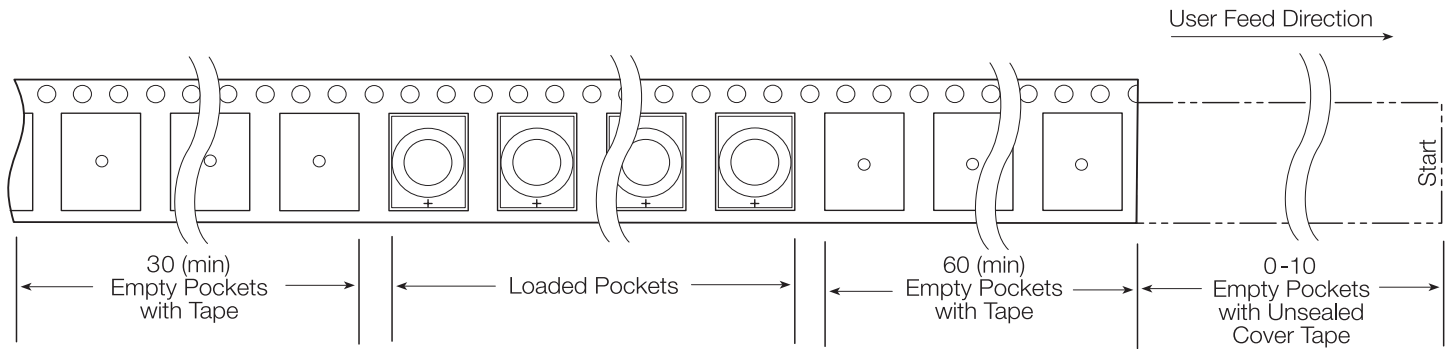
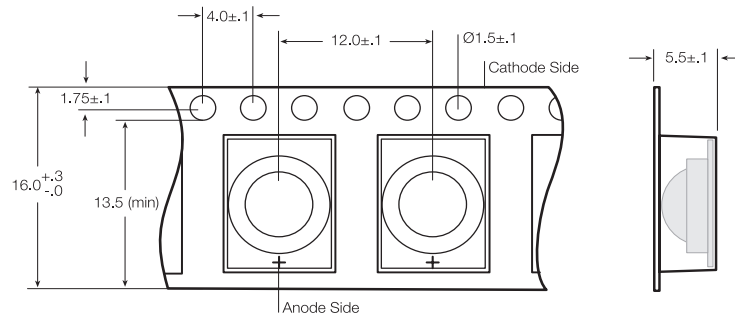

**Dry Packaging and Packaging**

